

Putzmeister

Stationary concrete pump

BSA 1407 D

Output up to 71 m³/h
 Delivery pressure up to 106 bar

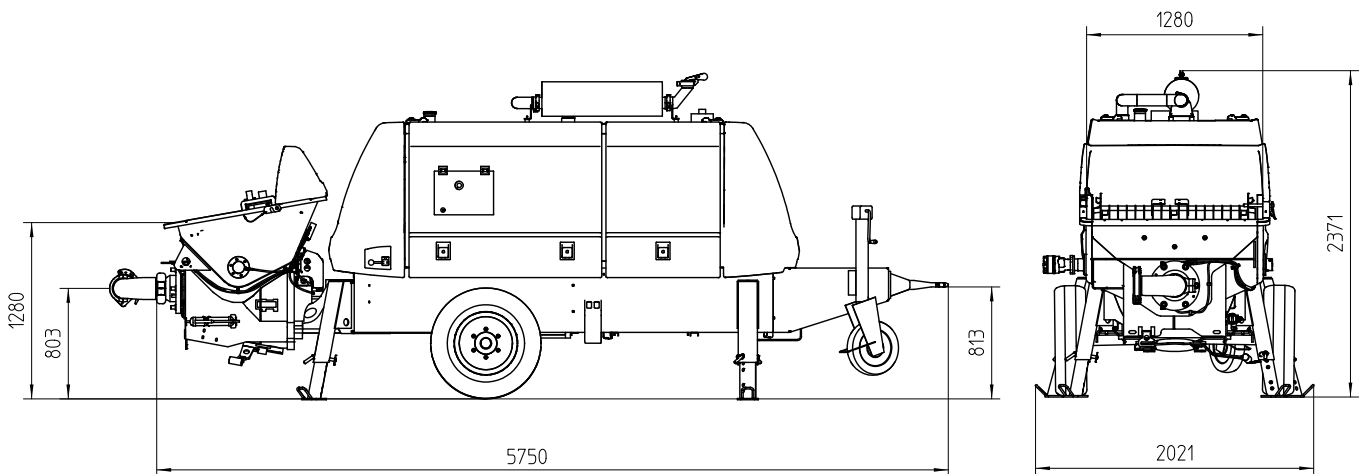

Note: Standard version. Dimensions and weights depend on equipment.

Performance diagram

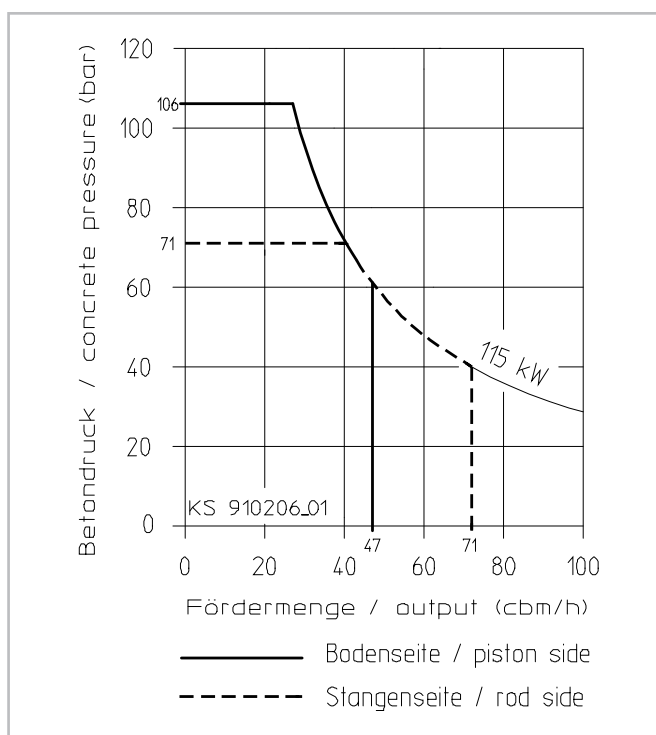

Technical data

Model	BSA 1407 D	
Material number	102340.000	
Output	m ³ /h	71 / 47 *
Delivery pressure	bar	71 / 106 *
Delivery cylinder	Ø mm	200
Delivery cyl. stroke	mm	1400
Strokes / minute	27 / 18 *	
Engine power	kW	115
Hopper	RS 909	
Capacity	l	ca. 600
Filling height	m	1.3
Transfer tube	S 2015 D	
Line connection	mm	SK 125
Pressure connection	"	5.5
Control system	SPC-OPS	
Weight	kg	4260

* Values for hydraulic fluid being fed to piston-side
 All data maximum theoretical

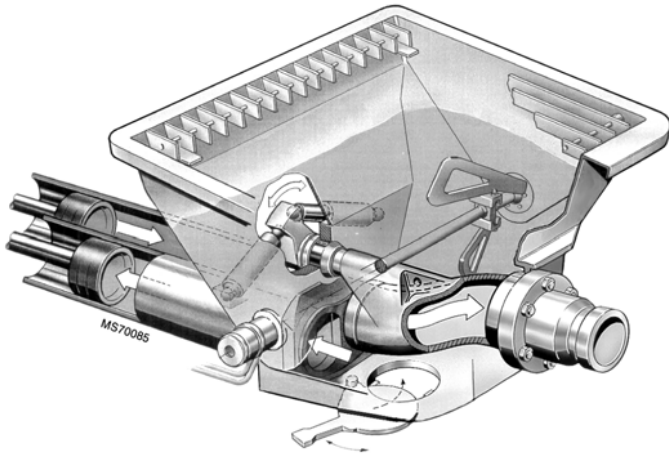

Hopper with transfer tube

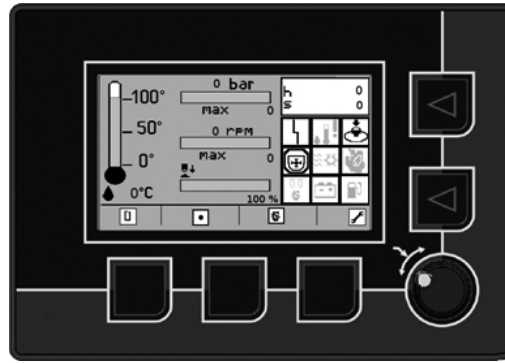

EGD - Ergonic Graphic Display

Serial equipment

Agitator safety switch off
Cable remote control 10 m
Central lubrication on hopper with hand lever press
Cleaning accessories
Coloring: Cover chrome yellow / black Pump, frame and trailer light-grey Roof and splash guard black-grey
Concrete hopper with agitator
Coupling ring (DIN)
Drive diesel, Deutz 115 kW
Flushing water pump 50 l/min 20 bar
Gate valve connection
Grill 70 mm
Operating manuals (1 x paper, 1 x CD-ROM) spare part list
Outriggers 4 x mech.
Reduction bend 90°; SK 150 -> SK 125
Splash guard
Support wheel
Tool set incl. standard equipment
Trailer F8, travelling in site

Ergonic equipment

Electronic error management
Ergonic Graphic Display (EGD)
Speed drawdown automatically on pump stop

See quotation for exact serial delivery scope.
Comprehensive range of options available on request.