

Putzmeister

Concrete pump

BSA 1005 D

Output up to 52 m³/h
 Delivery pressure up to 70 bar

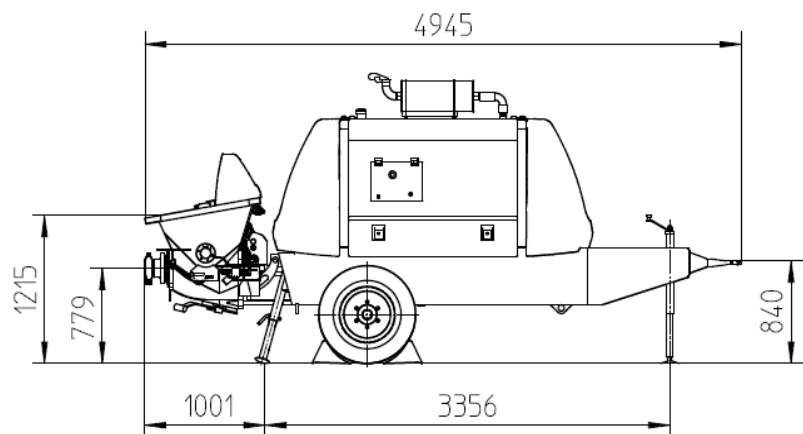
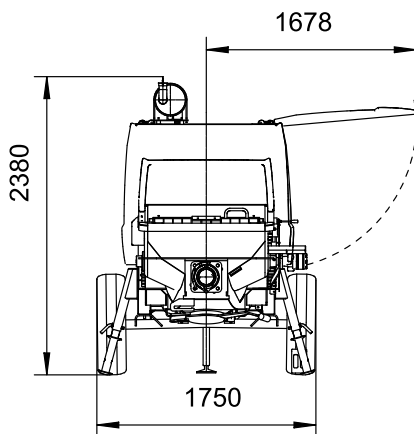

Note: Standard diesel version. Dimensions and weights depend on equipment.

Performance diagram

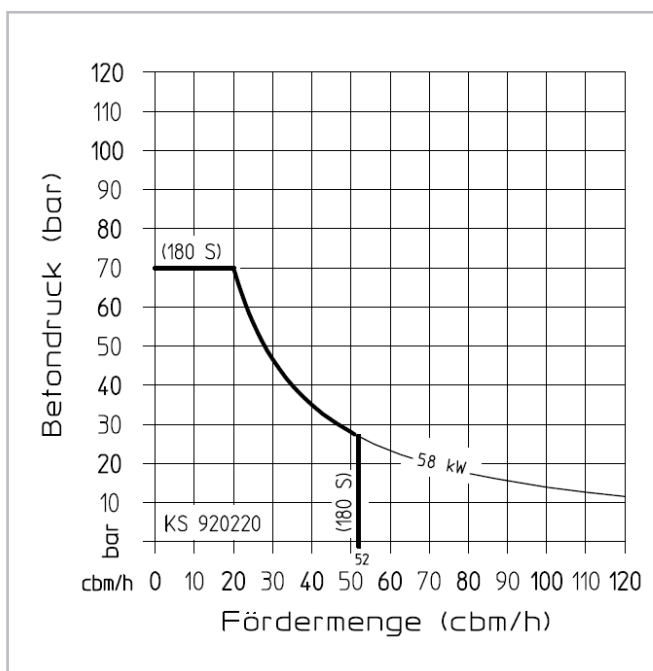

Technical data for concrete pump

BSA 1005 D		Material number 102310.000
Output	m ³ /h	52
Delivery pressure	bar	70
Delivery cylinder	Ø mm	180
Delivery cyl. stroke	mm	1000
Strokes / minute		35
Engine / motor power	kW	58
Hopper		RS 487K
Capacity	l	approx. 350
Filling height	m	1.2
Transfer tube		S 1812
Line connection	mm	SK 125
Pressure connection	"	5.5
Control system		OPS
Weight	l	120
Gewicht	kg	2900

All data maximum theoretical

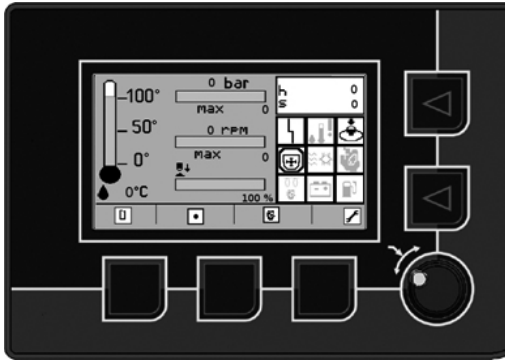

EGD - Ergonic Graphic Display

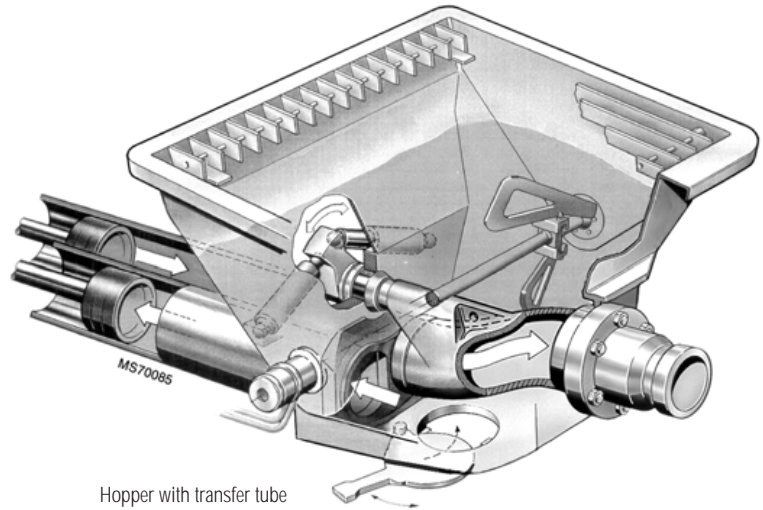

Hopper with transfer tube

Delivery scope

Drive diesel, Deutz 4-cyl.-turbo engine, 58 kW,
electronic engine management

Concrete hopper with agitator

Operating manuals (2 sets), spare part lists

Tool set incl. standard equipment

Trailer F8, can be driven on job site

Central lubrication on the hopper with
hand lever grease gun

Grill 70 mm

Cleaning accessories

Splash guard

Support leg on tow bar

Coupling ring (DIN)

Coloring:

Cover MB 1227 chrome yellow / black

Pump, frame and trailer RAL 7035 light-grey

Roof and splash guard RAL 7021 black-grey

Ergonic equipment

Speed drawdown automatically on pump stop (EPS)

Ergonic Graphic Display (EGD)

Electronic error management

See quotation for exact serial delivery scope.
Comprehensive range of options available on request.